



# Use Of C-Filter Plugs

## Introduction

The C-Filters (p/n 024-2004-000) are cellulose fiber filter plugs (not to be confused with carbon filters). They are installed on RAE monitors either in a separate cartridge with Luer-Lock fittings (p/n 024-2000-000 for MultiRAE series, QRAE series, etc.) or directly in the probe (VRAE, MiniRAE series, ppBRAE, etc.). For optimum filtering and protection from drawing in liquids, the C-filter should be attached in series with the water trap filter.

## Moisture & Dust Removal

The C-filter removes dust and moisture, protecting the pump and sensors. The filter will not reduce the bulk humidity substantially, but in highly humid environments it will reduce it enough to reduce condensation on the sensor. Condensation on PID sensors causes a leak current resulting in a slowly rising false positive response that may reach several ppm or even several hundred ppm. To prevent such false response, thoroughly clean the sensor with methanol in an ultrasound bath and the lamp housing and ensure that the sensor electrodes (interdigital fingers contacting the lamp) are not bent or corroded. Microparticles of dust absorb moisture more readily than a clean surface, causing the leak current when a dirty sensor is combined with a very humid sample stream. Using the C-filter extends the time between necessary cleanings, by reducing both dust build-up and water condensation. The filter continues to absorb water mist for an extended time (see Figure 1) but will eventually become saturated.

## Replacement Frequency

We recommend replacing the C-filter weekly in normal use and daily in especially dusty or humid environments.

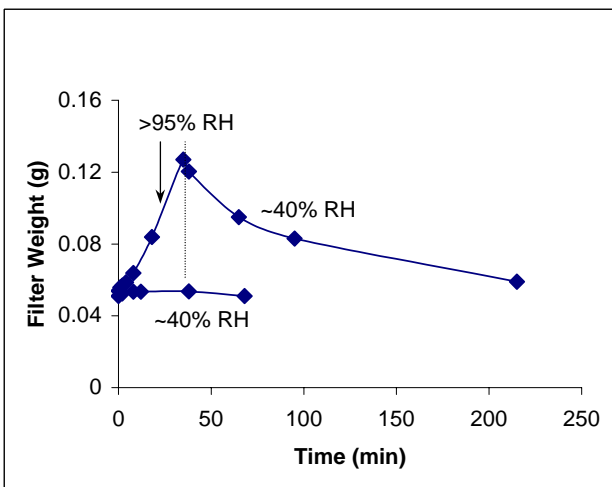

Figure 1. C-filter water absorption in humid air when connected to a MiniRAE 2000.

## Precautions

The C-filter allows most permanent toxic gases and many light, volatile organic compounds (VOCs) to pass unaffected (Figures 2 & 3). Tests with CO, H<sub>2</sub>S, NH<sub>3</sub>, Cl<sub>2</sub>, ClO<sub>2</sub>, PH<sub>3</sub>, HCN, NO, and NO<sub>2</sub> showed no significant effect on sensor response or response time.

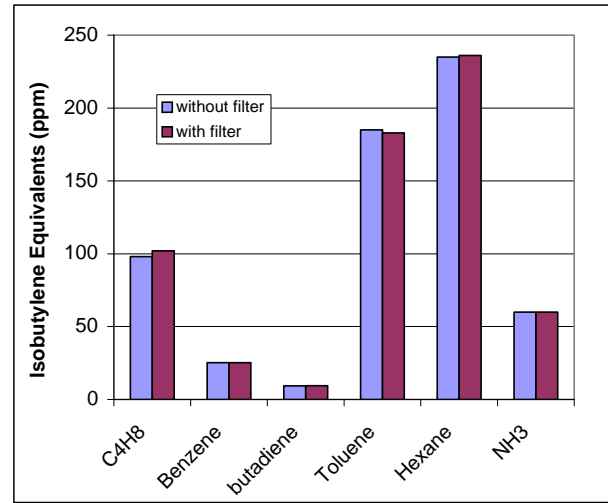

Figure 2. C-filter test on VOCs with MiniRAE 2000.

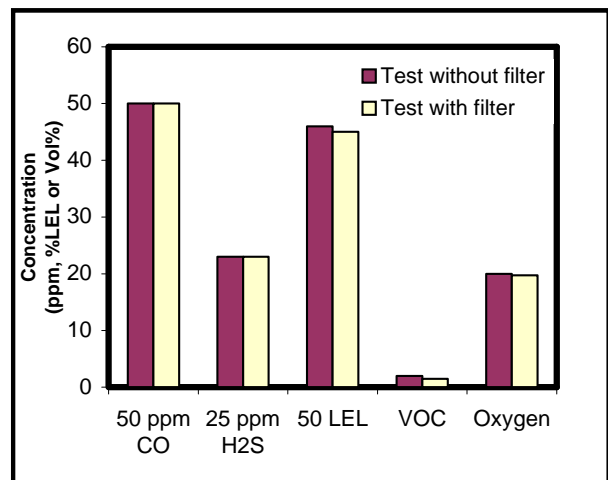

Figure 3. C-filter test on toxic gases with MultiRAE.

However, heavy or reactive compounds will give slowed response and may be partially lost on the filter. Therefore the filter should not be used for such compounds. For example, Figures 4 and 5 show the effect of the filter on the responses of acetic anhydride and dimethylacetamide, respectively. Compounds like dimethylacetamide and





Dowtherm A are partially retained by absorption to the filter, while others like acetic anhydride, tolylene diisocyanate (TDI) and phosgene are consumed by reaction with the filter material.

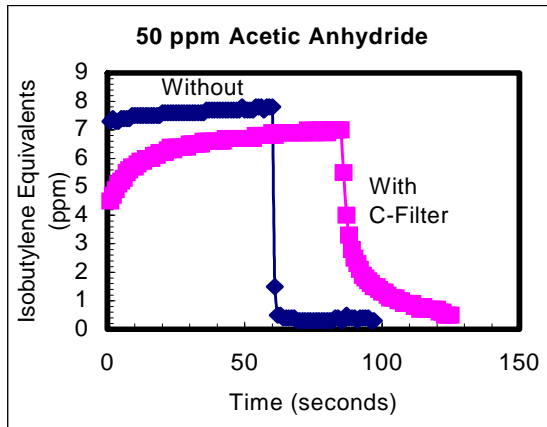

Figure 4. C-Filter effect on acetic anhydride response.

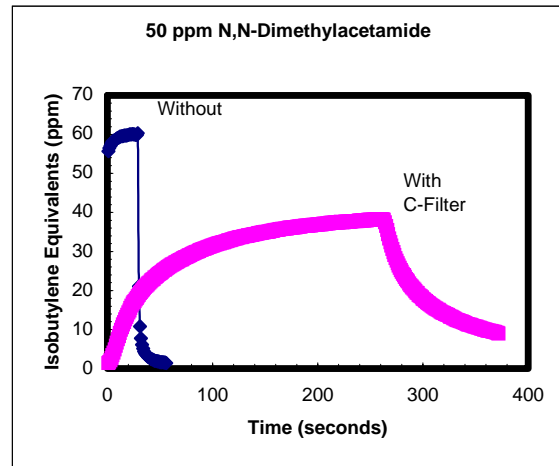

Figure 5. C-Filter effect on dimethylacetamide response.

Table I. Compounds tested with C-filter

Compound	Effect on Response	Effect on Response Time*
CH <sub>4</sub> , O <sub>2</sub> , CO, H <sub>2</sub> S, NH <sub>3</sub> , Cl <sub>2</sub> , ClO <sub>2</sub> , PH <sub>3</sub> , HCN, NO, NO <sub>2</sub> ,	None	None
Isobutylene, Butadiene, Benzene, Hexane,	None	None
Ethanol, Gasoline, Pyridine, Toluene	<10%	Minor
Acetic anhydride, Kerosene (JP-8)	≤15%	Medium
N,N-Dimethylacetamide, Dowtherm A, Tolyene diisocyanate (TDI), Tributyl phosphate	>20%	Large

\*t<sub>90</sub> response time is approximately 3 sec for None, 5-20 sec for Minor, 30-60 sec for Medium, and 1- >5 min for Large using a MiniRAE 2000 for VOCs. Response time for toxic gas sensors (first row) depends on the sensor.

## Installation

For MiniRAE 2000, VRAE, and ppbRAE, the C-Filter can be installed in the probe as shown below. For other platforms the filter can be installed in the C-Filter holder (p/n 024-2000-000) and attached to the Luer-Lock fitting on the inlet or the Water Trap filter.

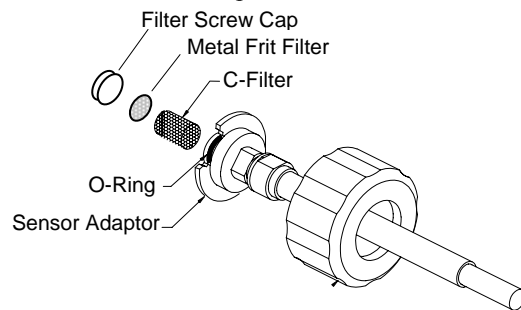

Figure 6a. C-Filter Installation in MiniRAE 2000, ppbRAE, and VRAE style probe

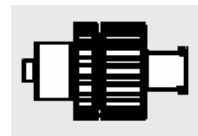

Figure 6b. C-Filter housing for MultiRAE and QRAE style probe.