

## Electrochemical Sensor Replacement & Maintenance

This technical note describes sensor replacement and maintenance procedures for electrochemical and combustible gas (LEL/TC) sensors used in RAE Systems instruments, including MultiRAE, QRAE, and VRAE. For technical specifications of sensors, see Technical Note TN-114, and for handling LEL sensor poisons, Technical Note TN-144. For CO sensor cross-sensitivity and filters, see Technical Note TN-121.

### General

- Prepare a clean workspace and wash hands well before installing sensors. Greases and oils can cause sensors to perform poorly. LEL sensors are particularly sensitive to damage from silicone lubricants, including hand lotions.
- Turn off the power to the unit and remove the instrument cover.
- Disconnect the battery before replacing a sensor.



**Warning:** Failure to turn off the power during replacement can cause damage to some sensors. Failure to disconnect the battery can cause the non-replaceable fuse in the battery to blow.

### Sensor Replacement Procedures

Remove the gas distribution plate, if any. Carefully pull the existing sensor straight out.

- Some electrochemical sensors are shipped with a shorting spring connecting two of the large pins to keep the sensor stabilized during storage. Remove any shorting spring before installing the new sensor.

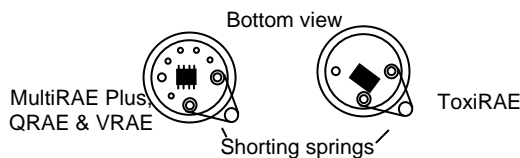

Replace the spring if the sensor is removed from the instrument for more than several minutes. Lack of a shorting wire will not damage the sensor, but if it is missing for more than about 10 minutes, the sensor may require an hour or more to fully equilibrate after being installed. Biased and LEL sensors do not have shorting springs.

- Insert the sensor by carefully lining up the sensor pins with the sockets in the circuit board. To avoid damaging the internal contacts, use caution and do not bend the pins on the sensor. Bent sensor pins can be carefully bent back using long-nose pliers.
- Do not push the sensors down too hard while installing, as this may cause damage to the circuit board components underneath the sensor.
- After reassembly, the unit may go into alarm if turned on immediately. Allow about 10 minutes for the sensor to stabilize in the unit before turning on the instrument. For maximum accuracy, non-biased toxic sensors should be allowed to stabilize for one hour before calibrating. Biased sensors require a 24-hour stabilization time with batteries installed.
- Re-zero and recalibrate new sensors prior to use.

### Biased Sensors (NO)

Nitric Oxide (NO) sensors require a voltage bias and must be installed in position 1 of the MultiRAE Plus and positions 1 through 3 of the VRAE, and the bias switch must be turned *on*. See the figures at the end of this Technical Note for the positions of the bias switches and sensors.



**Warning:** Failure to install NO sensors in the biased position can damage the sensors. Using shorting springs on bias-type sensors can damage the sensors.

Biased sensors require a 24-hour stabilization time with batteries installed. If you receive a new unit with this sensor, install the batteries and wait overnight before attempting to calibrate the sensor. Units with rechargeable batteries must be kept at minimal charge to main the bias on the sensor. If the sensors or batteries are disconnected for more than a few seconds, it may require several hours to again stabilize the sensor.

### Recalibration

The MultiRAE remembers the last calibration on a given sensor position. If a sensor is traded out, the new sensor needs about one hour to equilibrate, and it must then be recalibrated. In the case of a sensor with an electrical bias (NO), it must equilibrate about 24



hours before calibrating. We recommend calibrating whenever a sensor is removed, even if the same sensor is reinstalled in the same location.

## Filters

It is good practice to replace filters at the same time a sensor is replaced. Filters may need replacement more frequently if clogged or saturated. Filter replacement is indicated when the sensor begins to respond slowly or take a long time to recover from an exposure. In addition to the instrument inlet filters designed to remove particles and water droplets, some sensors (for example, CO) need other external filters for proper operation.

- **ToxiRAE membrane filter & MultiRAE/QRAE filter cartridges.** Replace when visibly dirty or when sensor response become slow.
- **CO sensor carbon filter.** Replace when response to organic vapors is noted or every six months, whichever comes first. This filter is located in the MultiRAE, VRAE or QRAE cover plate.
- Remove the carbon filter if another sensor is used to replace a CO sensor. For example, if an SO<sub>2</sub> or Cl<sub>2</sub> sensor is installed, the carbon filter removes these gases and low readings are obtained.



**Warning:** Failure to remove the carbon filter in the MultiRAE Plus cover plate for sensors other than CO may result in low readings.

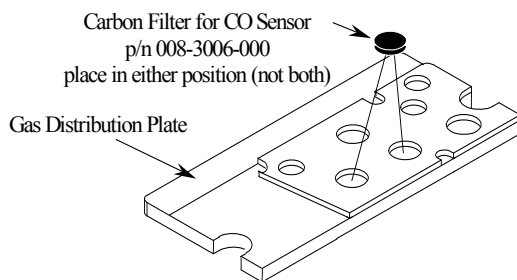

## Storage

Sensors can dry out or burst if stored at very low or very high relative humidity, respectively. To maximize sensor life, store sensors and instruments indoors in a climate-controlled building. Note other special conditions:

- Cl<sub>2</sub> sensors are particularly sensitive to high relative humidity and may burst if stored in a refrigerator.
- Oxygen sensors are always on and are being consumed by ambient air. These sensors are shipped in oxygen-impermeable bags. The shelf life can be extended by keeping the sensor in the impermeable bag until it is used.
- Replace shorting springs on non-biased sensors for rapid start-up when reinstalled.
- Store LEL sensors away from possible catalyst poisons such as silicone-containing greases or rubbers, sulfur compounds, and chlorine compounds.
- The plastic containers used to ship sensors are not air-tight and do not provide long-term protection from humidity extremes, O<sub>2</sub>, or LEL poisons.

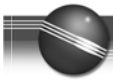

## Bias Switch Locations

Nitric Oxide sensors should be placed in position 1 on the MultiRAE and positions 1 to 3 on the VRAE. The MultiRAE Plus uses a jumper moved from the right two pins to the left two pins to turn on the bias. The VRAE uses three switches pushed up towards the sensors to turn on the bias. The MultiRAE can have one biased sensor and the VRAE up to three.

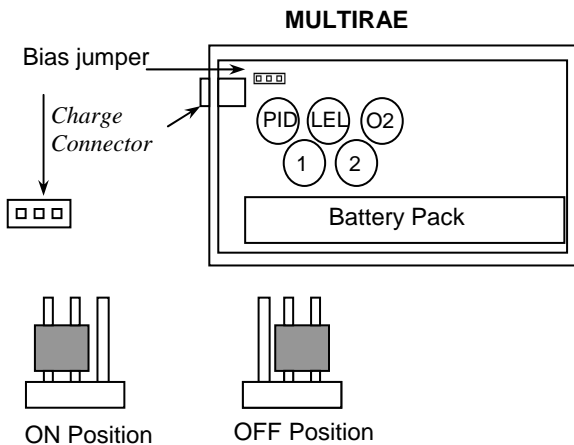

**MultiRAE top view with cover plate removed showing location of bias jumper and sensor positions.**

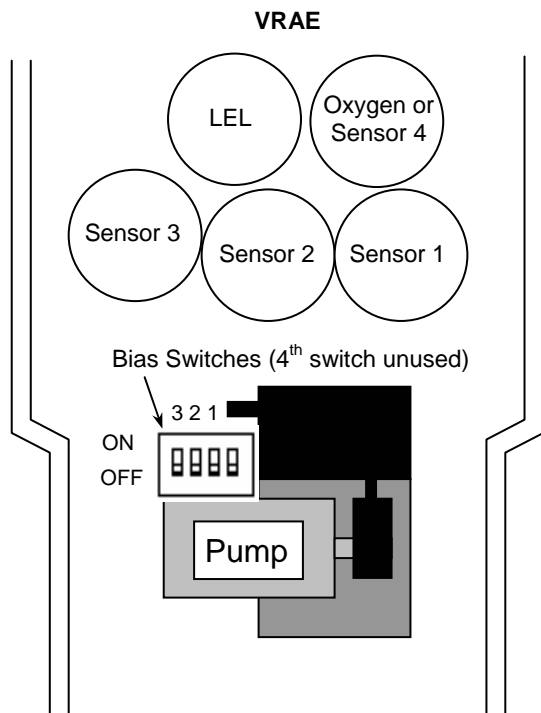

**VRAE Internal view showing location of bias switch position and sensor positions**

## Interchangeability

### Single Sensor in Different Instruments

- Sensors for the MultiRAE, QRAE, QRAE Plus, and VRAE are interchangeable among instruments, except for the LEL/VOL sensor. The MultiRAE and QRAE use the 4R sensor only (p/n 008-1171-002), the VRAE uses either the 4R (p/n 017-1171-000) or 4R/TC sensor (p/n 017-1172-000), and the QRAE Plus uses the 3R/TC sensor (p/n 016-1171-000 or 016-1172-000). The CO<sub>2</sub> sensor can only be used in the MultiRAE IR.

### Different Sensors in a Single Instrument

- In the MultiRAE and VRAE, all sensors including the HCN and PH<sub>3</sub> sensors (p/n 008-1117 and 19) *are* interchangeable. Thus, any combination of sensors is possible, except that the MultiRAE can have only one biased sensor (NO) because there is only one bias position. In the VRAE, sensors with a negative current (NO<sub>2</sub>, Cl<sub>2</sub>, and ClO<sub>2</sub>) cannot be placed in position 3, and in the VRAE, sensors with a bias or negative current cannot be placed in position 4 (see table below).
- The QRAE is limited to the four standard sensors LEL/O<sub>2</sub>/CO/H<sub>2</sub>S.

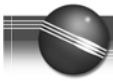

Sensors		PGM-7800		PGM-7840	
Gas	Bias	Tox1,2 Loc.	Tox3 Loc.	Tox1,2,3 Loc.	Tox4 Loc.
CO	Off	OK	OK	OK	OK
H <sub>2</sub> S	Off	OK	OK	OK	OK
SO <sub>2</sub>	Off	OK	OK	OK	OK
NO	On	OK bias on	OK bias on	OK bias on	Not allowed
NO <sub>2</sub>	Off	OK	Not allowed	OK	Not allowed
Cl <sub>2</sub>	Off	OK	Not allowed	OK	Not allowed
ClO <sub>2</sub>	Off	OK	Not allowed	OK	Not allowed
NH <sub>3</sub>	Off	OK bias off	OK bias off	OK bias off	OK bias off
HCN	Off	OK	OK	OK	OK
PH <sub>3</sub>	Off	OK	OK	OK	OK

### Extended Calibration Times

Slowly responding sensors listed in the table below may require pre-exposure of the sensor to the gas immediately before initiating the calibration sequence. Some firmware versions use a fixed 60-second calibration time; some newer versions automatically apply the full calibration time. After completing the

zero calibration, expose the unit to the gas for the pre-exposure time listed below if a 60-second countdown time is programmed in the unit. In many cases when a pre-exposure is performed, the unit gives a warning message “No gas...” when calibration is initiated. Simply push the [Y/-] button to bypass the warning and proceed with the calibration.

Sensor	Response Time t <sub>90</sub> (sec)	Total Calibration Time (sec)	Pre-exposure Time for 1-min Calibration Time
HCN	200	230	170
ClO <sub>2</sub> , NH <sub>3</sub> , COCl <sub>2</sub>	150	150	90
Cl <sub>2</sub> , PH <sub>3</sub>	60	120	60
CO, H <sub>2</sub> S, SO <sub>2</sub> , NO, NO <sub>2</sub> , O <sub>2</sub> , LEL, VOL	≤40	60	0