

# RAEGuard S

## Permanently Installed Gas Detector



**Stainless-steel enclosure**

**Offline calibration**

**Non-intrusive calibration**

**Analog and digital communication**

**Local display**

The RAEGuard S is a permanently installed gas detector for hydrocarbon combustible gases, carbon dioxide and a wide range of toxic gases. It is a flexible detector which provides both an analog (4-20mA) and digital (RS-485, ModBus RTU) output signal. The RAEGuard S uses a smart sensor which can be off-line pre-calibrated. An explosion-proof stainless steel enclosure and magnetic key non-intrusive operation make the RAEGuard S ideal for use in hazardous environments. The RAEGuard S is equipped with a local digital display and LEDs for viewing of gas concentration and alarm conditions.

### Key Features

- **Easy to Use**
  - Magnetically accessed keys for non-intrusive calibration
  - Designed for easy access to sensor
  - Local digital display with alarm indication
- **Flexible**
  - RS-485 digital communication in ModBus protocol
  - Adjustable 4-20mA analog output
  - Operation at 9 to 36VDC
  - 2 programmable alarm relays
- **Durable**
  - Long-life sensor
  - Explosion-proof stainless-steel enclosure
- **Advanced Technology**
  - Smart NDIR, Catalytic or Electrochemical sensors
  - Offline calibration
  - Quick response sensors

### Applications

- Waste water treatment plants
- Petroleum and natural gas fields
- Marine and off-shore oil wells
- Refineries and petrochemical plants
- Pulp and paper plants
- Chemical plants
- Power plants
- Steel mills



ATEX



# RAEGuard S

## Specifications

### Sensor Specifications

Gas	Range	Resolution
Hydrogen Sulfide (H <sub>2</sub> S)	0 to 300 ppm	1 ppm
Carbon Dioxide (CO <sub>2</sub> )	0 to 50,000 ppm	10 ppm
Methane (CH <sub>4</sub> )	0 to 100% LEL	1% LEL
Hydrocarbons (HC)	0 to 100% LEL	1% LEL
Carbon Monoxide (CO)	0 to 1000 ppm	1 ppm
Oxygen (O <sub>2</sub> )	0 to 30% VOL	0.1% VOL

\*Other sensors: contact manufacturer

### Detector Specifications

Size	6.6" L x 5.9" W x 4.3" H (16.8cm x 15cm x 10.9cm)
Weight	7.7 lbs (3.5 kg)
Detector	Protected, Off-line pre-calibrated, interchangeable smart NDIR sensor
Calibration	Two-point calibration
Accuracy	≤ ± 5% FS
Response Time (T <sub>90</sub> )	≤ 30 seconds to 90% of reading to span gas
Enclosure Rating	ATEX: Ex II 2 G Ex d II C T6 China Certification: Ex d II C T6
IP Rating	IP-65
Power	9 to 36VDC, max 60mA at 24V or 1.5W
Output	4-20mA, RS-485 ModBus RTU (Baud rate of 4.8, 9.6, or 19.2 Kb/s)
Sampling	Internal diffusion
Display	7-segment, 4-digit LCD (if the reading digits are more than 4, LCD will display "X.XEX" for X.X x 10 <sup>n</sup> )
User Interface	4 color-coded alarm LEDs Magnetically accessed keys for non-intrusive calibration and adjustment
Operating Temperature	-40° F to 140° F (-40° C to 60° C)
Humidity	0 to 95% relative humidity (non-condensing)
Pressure	0.9 to 1.1 ATM
Dry Contacts	Max 30V, 2A, normally open (or normally closed), one for low and high alarm, and another for faults
Terminal	AWG24-12
Mounting	2 holes 5.25" (13.3cm) from center to center

Specifications are subject to change

[www.raesystems.com](http://www.raesystems.com)

**RAE Systems Inc.**  
3775 North First Street  
San Jose, CA 95134 USA  
raesales@raesystems.com

USA/Canada 1-877-723-2878  
Europe/Russia +45 8652 5155  
Middle East/Australia +971 4 887 5562  
China +86 10 5885 8788  
Asia +852 2669 0828

DS-0000-00

## RAEGuard S Ordering Information

### RAEGuard S Basic Kit

- RAEGuard S detector with smart sensor as specified
- Installation, operation and maintenance manual
- Magnetic key
- Calibration adapter

### Installation Drawing

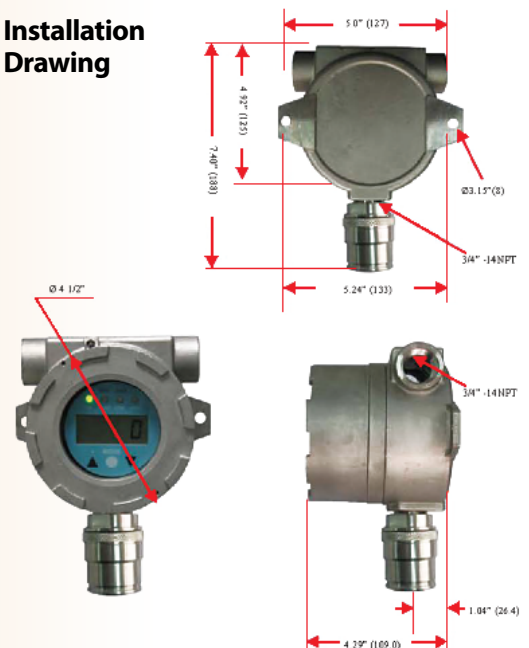

## Ordering Information

### Part Numbers

Kit Description	Range	Part Number
RAEGuard S IR CO <sub>2</sub> , FGM-1200S	0 to 50,000 ppm	036-0807-000
RAEGuard S IR LEL, FGM-1200S	0 to 100% LEL	036-0806-000
RAEGuard S Catalytic LEL, FGM-1100S	0 to 100% LEL	036-0805-E00
RAEGuard S EC CO, FGM-1300S	0 to 1000 ppm	036-0805-E20
RAEGuard S EC O <sub>2</sub> , FGM-1300S	0 to 30% VOL	036-0805-E70
RAEGuard S EC H <sub>2</sub> S, FGM-1300S	0 to 300 ppm	036-0805-E10

\*Calibration adapter and adjustment magnet are included.

**Toll-Free: 877-723-2878**

